

Top Wing - wing root dihedral guage
Lower Wing - wing root dihedral guage

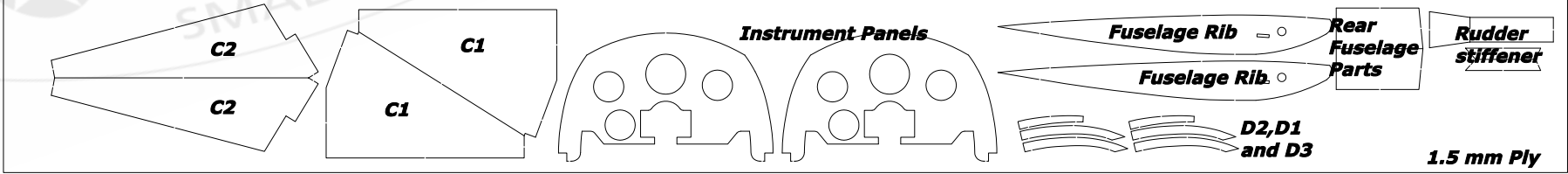

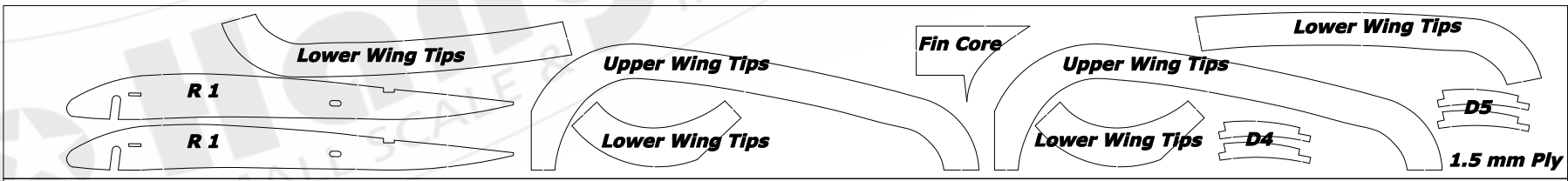

0.6 mm Ply

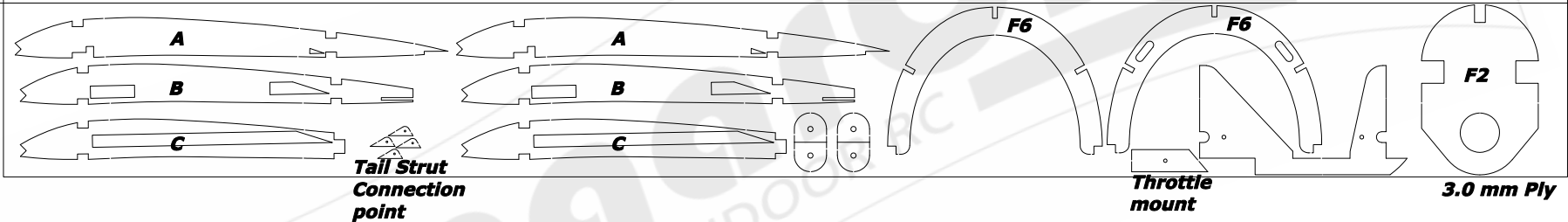
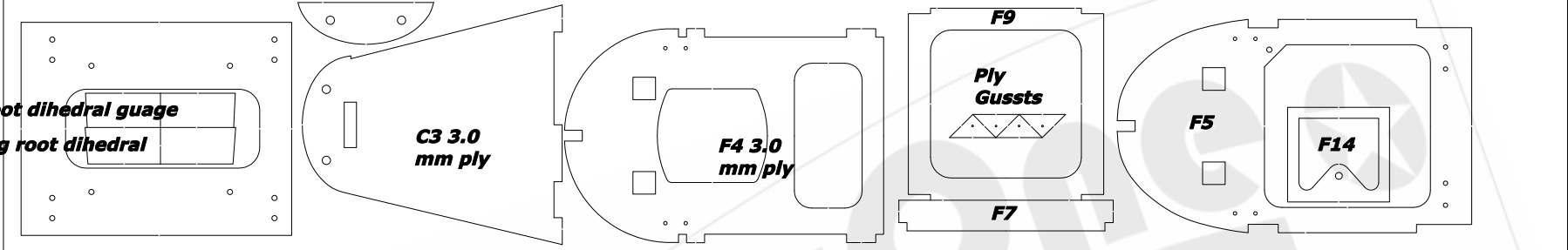
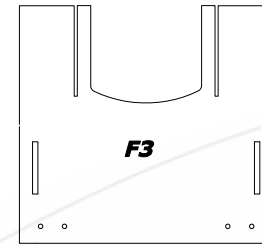
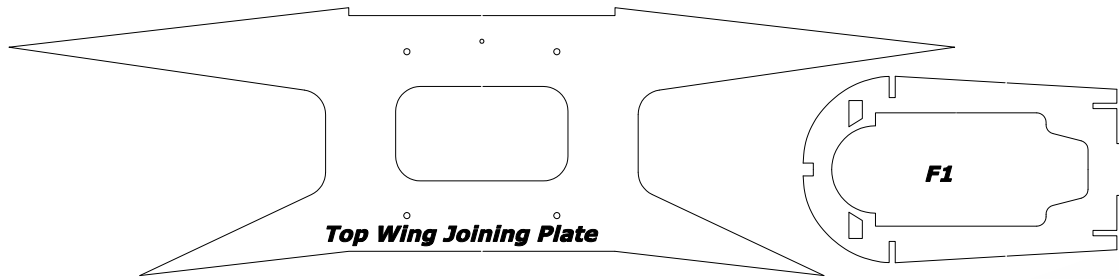
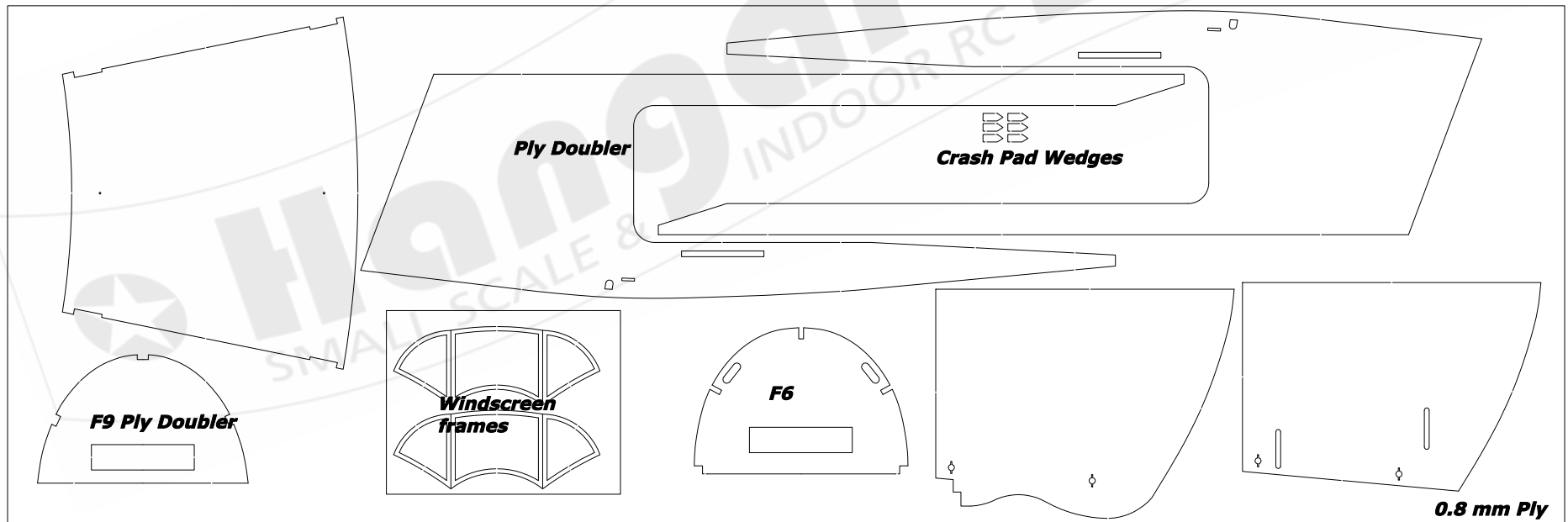
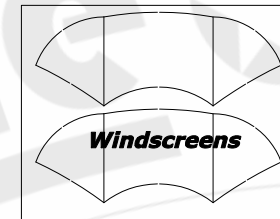

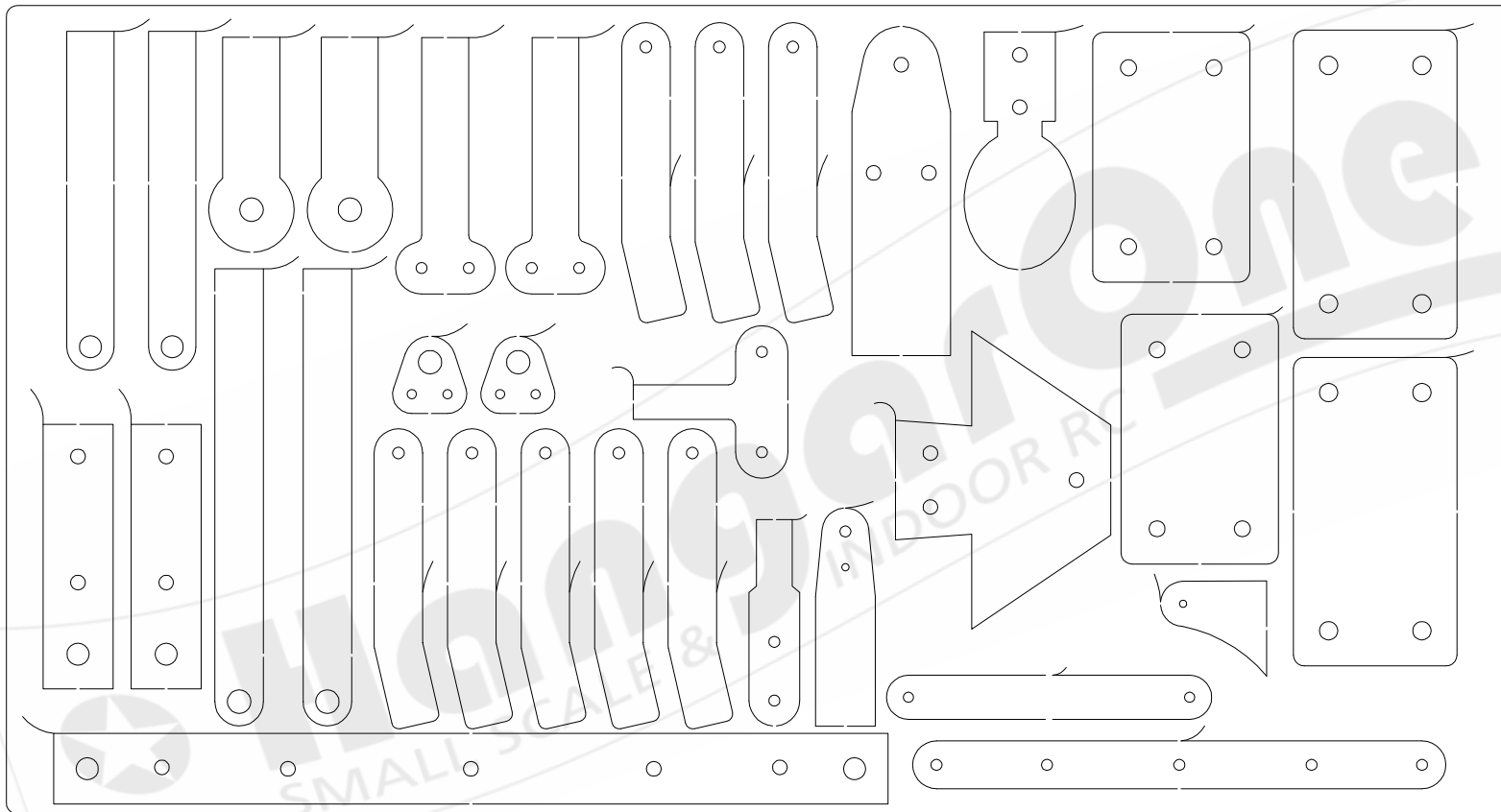

1.2mm / 18 swg Mild Steel